

Quality is designed into Series 200, 225, and 250 butterfly valves from Center Line. These valves feature a phenolic-backed cartridge seat and precision-machined parts to assure years of dependable operation.

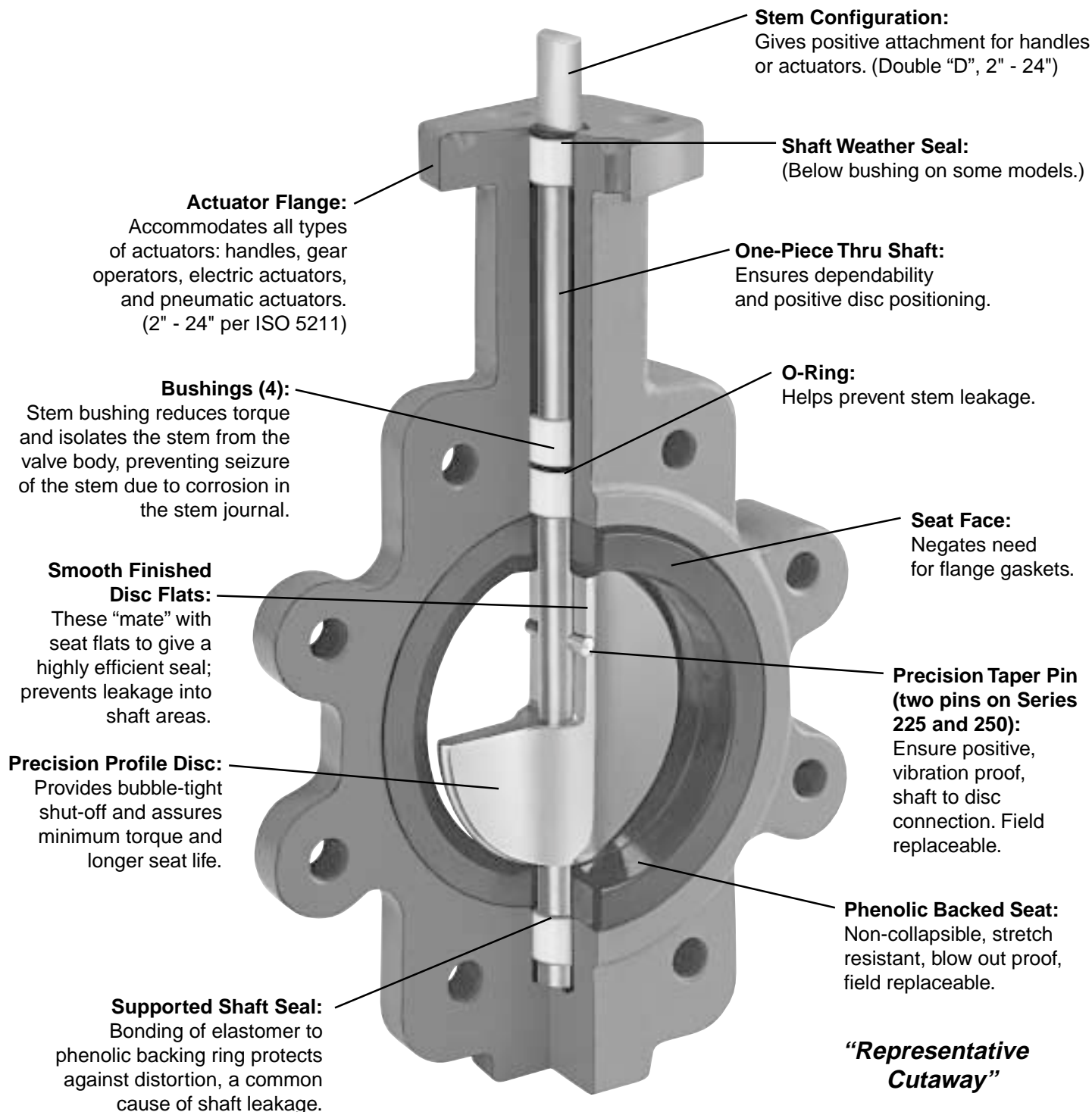

**Stem Configuration:**  
Gives positive attachment for handles or actuators. (Double "D", 2" - 24")

**Shaft Weather Seal:**  
(Below bushing on some models.)

**Actuator Flange:**  
Accommodates all types of actuators: handles, gear operators, electric actuators, and pneumatic actuators. (2" - 24" per ISO 5211)

**One-Piece Thru Shaft:**  
Ensures dependability and positive disc positioning.

**Bushings (4):**  
Stem bushing reduces torque and isolates the stem from the valve body, preventing seizure of the stem due to corrosion in the stem journal.

**O-Ring:**  
Helps prevent stem leakage.

**Smooth Finished Disc Flats:**  
These "mate" with seat flats to give a highly efficient seal; prevents leakage into shaft areas.

**Seat Face:**  
Negates need for flange gaskets.

**Precision Profile Disc:**  
Provides bubble-tight shut-off and assures minimum torque and longer seat life.

**Precision Taper Pin (two pins on Series 225 and 250):**  
Ensure positive, vibration proof, shaft to disc connection. Field replaceable.

**Phenolic Backed Seat:**  
Non-collapsible, stretch resistant, blow out proof, field replaceable.

**Supported Shaft Seal:**  
Bonding of elastomer to phenolic backing ring protects against distortion, a common cause of shaft leakage.

**"Representative Cutaway"**

- Available in sizes 2" to 24".
- Pressure Rating: 285 psi at 100°F. Pressure/Temperature rating above 100°F corresponds to ANSI B16.5 Class 150 for steel flanges.
- Available in Wafer or Lug style body.
- Wafer body features four alignment holes.
- Available in ANSI Class 300 Lug Body bolt pattern (2"-12").
- Ideal for on-off or throttling services.
- Available with handles (2" to 6"), manual gear operators, electric actuators and pneumatic actuators (2" to 24").
- Refer to Crane actuator bulletin for details of pneumatic and electric actuators.
- Compatible with ANSI B16.1 Class 125 (Iron) and ANSI B16.5 Class 150 (Steel) flanges or optional Class 300 (Steel) Lug only.
- Bi-directional dead-end capability to 200 psi (2" to 12") and 150 psi (14" to 24") is an available option.
- Valves 14" and larger are rated at a maximum 150 psi when a companion flange is not used in dead end service.
- For bolting information, consult the Center Line Installation and Maintenance Manual.

## Valve Seating Torques (In-Lbs.)

Valve Size	Standard Disc Differential Pressure				
	50 PSI	100 PSI	150 PSI	200 PSI	285 PSI
2"	136	142	148	154	164
2 1/2"	152	160	168	176	189
3"	224	229	234	239	247
4"	380	392	404	416	436
5"	451	477	503	529	572
6"	875	946	1016	1087	1206
8"	1476	1559	1642	1726	1867
10"	2451	2613	2775	2937	3213
12"	3900	4111	4323	4534	4893
14"	5189	5467	5744	6022	6494
16"	10,985	11,569	12,154	12,738	13,732
18"	13,946	14,688	15,431	16,173	17,434
20"	14,695	15,478	16,260	17,043	18,373
24"	29,738	31,321	32,903	34,486	37,176

All torques shown on the chart were derived from test data using water at 60°F. For torques using dry gases, multiply these numbers by 1.6. For torques involving other media, please consult the factory.

There is no safety factor included in the numbers shown on this chart. For actuator sizing, Center Line recommends that these values be multiplied by 1.2 for single valve applications, or 1.5 for 3-way ("tee") applications.

For PTFE seats multiply the numbers shown on this chart by 2.0.

Under certain conditions, hydrodynamic torque can meet or exceed seating and unseating torques. When designing valve systems, hydrodynamic torque must be considered to help assure correct selection for the application.

## Seat Temperature Ratings

Material	Temperature Rating °F
Buna-N	+10 to 180
EPDM (2"-16")	-30 to 275
EPDM (18"-24")	-30 to 225
Abrasive Resistant Buna-N	+10 to 180
Neoprene	+20 to 200
Hypalon	0 to 275
Viton	+10 to 275
High Temperature Viton	+10 to 400

Although elastomers have an effective operating temperature range, when used in valves, these ranges may have to be modified. The temperature ranges shown in the table have been adjusted accordingly.

**For Low Temperature:** While the seat materials selected for use in Center Line butterfly valves are capable of withstanding lower temperatures without damage, the durometer of the elastomer is changed. This "hardening" of the seat may increase the operating torque beyond the structural limits of the stem and/or the disc to stem configuration.

**For High Temperature:** When using High Temperature Viton, the operating pressure of the valve is reduced above 275°F.

## C<sub>v</sub> Values – Valve Sizing Coefficients (US-GPM @ 1ΔP)

Size	10°	20°	30°	40°	50°	60°	70°	80°	90°
2"	0.06	3	7	15	27	44	70	105	115
2 1/2"	0.10	6	12	25	45	75	119	178	196
3"	0.20	9	18	39	70	116	183	275	302
4"	0.30	17	36	78	139	230	364	546	600
5"	0.50	29	61	133	237	392	620	930	1022
6"	0.80	34	94	153	257	422	706	1154	1320
8"	2	56	154	251	422	693	1158	1892	2165
10"	3	87	238	385	654	1073	1794	2931	3353
12"	4	153	417	681	1145	1879	3142	5132	5827
14"	6	183	500	816	1372	2252	3765	6150	7037
16"	8	271	740	1208	2031	3333	5573	9104	10,416
18"	11	318	867	1417	2382	3909	6535	10,676	12,215
20"	14	415	1133	1851	3112	5107	8538	13,948	15,959
24"	22	543	1482	2421	4069	6678	11,165	18,240	20,869

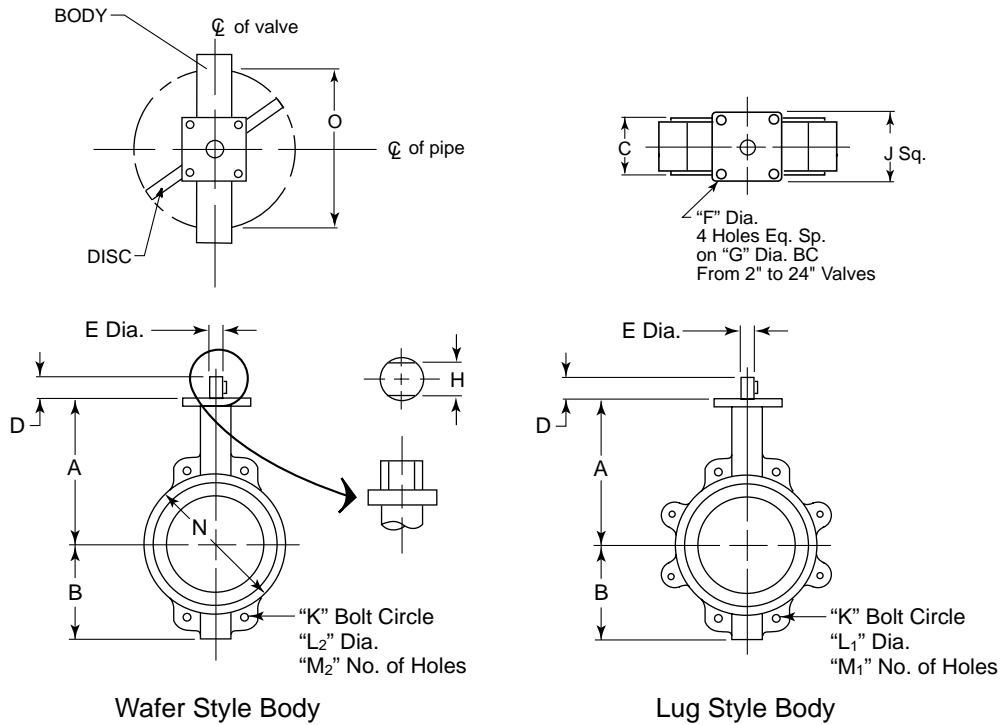

## Dimensions

Valve Size		A	B	C	D	E	F	G	H	J	K	300# K	L <sub>1</sub>	300# L <sub>1</sub>	L <sub>2</sub>	M <sub>1</sub>	300# M <sub>1</sub>	M <sub>2</sub>	WAFER	LUG	300# LUG	O
2"	in.	6 3/8	3 1/4	1 3/4	1 1/4	1/2	3/8	2.76	0.39	2 3/4	4 3/4	5	5/8-11	5/8-11	1 1/16	4	8	4	6 lbs.	9 lbs.	9 lbs.	1.26
50	mm	161.93	82.55	44.45	31.75	12.70	9.53	7.0	10	69.85	120.65	127.00		17.46		4	2.72 kg	4.09 kg	4.09 kg	32.0		
2 1/2"	in.	6 7/8	3 3/4	1 7/8	1 1/4	1/2	3/8	2.76	0.39	2 3/4	5 1/2	5 7/8	5/8-11	3/4-10	1 1/16	4	8	4	7 lbs.	13 lbs.	13 lbs.	1.83
65	mm	174.63	95.25	47.63	31.75	12.70	9.53	7.0	10	69.85	139.70	149.23		17.46		4	3.18 kg	5.90 kg	5.90 kg	46.5		
3"	in.	7 1/8	4	1 7/8	1 1/4	1/2	3/8	2.76	0.39	2 3/4	6	6 5/8	5/8-11	3/4-10	1 1/16	4	8	4	10 lbs.	14 lbs.	14 lbs.	2.54
75	mm	180.98	101.60	47.63	31.75	12.70	9.53	7.0	10	69.85	152.40	168.28		17.46		4	4.54 kg	6.36 kg	6.36 kg	64.5		
4"	in.	7 7/8	4 1/4	2 1/8	1 1/4	5/8	3/8	2.76	0.47	2 3/4	7 1/2	7 7/8	5/8-11	3/4-10	1 1/16	8	8	4	13 lbs.	19 lbs.	24 lbs.	3.54
100	mm	200.03	123.83	53.98	31.75	15.88	9.53	7.0	12	69.85	190.50	200.03		17.46		8	5.90 kg	8.63 kg	10.90 kg	89.9		
5"	in.	8 3/8	5 3/8	2 1/4	1 1/4	3/4	3/8	2.76	0.55	2 3/4	8 1/2	9 1/4	3/4-10	3/4-10	1 3/16	8	8	4	18 lbs.	22 lbs.	29 lbs.	4.36
125	mm	212.73	136.53	57.15	31.75	19.05	9.53	7.0	14	69.85	215.90	234.95		20.64		8	8.17 kg	9.99 kg	13.17 kg	110.7		
6"	in.	8 7/8	5 7/8	2 1/4	1 1/4	3/4	3/8	2.76	0.55	2 3/4	9 1/2	10 5/8	3/4-10	3/4-10	1 3/16	8	12	4	21 lbs.	31 lbs.	38 lbs.	5.74
150	mm	225.43	149.23	57.15	31.75	19.05	9.53	7.0	17	69.85	241.30	269.88		20.64		8	9.53 kg	14.07 kg	17.25 kg	145.8		
8"	in.	10 1/4	7 3/4	2 1/2	1 3/4	7/8	7/16	4.02	0.67	3 3/4	11 3/4	13	3/4-10	7/8-9	1 3/16	8	12	4	34 lbs.	49 lbs.	67 lbs.	7.63
200	mm	260.35	196.85	63.50	44.45	22.23	11.11	102	17	95.33	298.45	330.20		20.64		8	15.44 kg	22.25 kg	30.42 kg	193.8		
10"	in.	11 1/2	8 1/4	2 3/4	1 3/4	1 1/8	7/16	4.02	0.87	3 3/4	14 1/4	15 1/4	7/8-9	1-8	1 5/16	12	16	4	45 lbs.	72 lbs.	100 lbs.	9.54
250	mm	292.10	209.55	69.85	44.45	28.58	11.11	102	22	95.33	361.95	387.35		23.81		12	20.43 kg	32.69 kg	45.40 kg	242.3		
12"	in.	13 1/4	9 3/4	3 1/8	1 3/4	1 1/4	7/16	4.02	0.95	3 3/4	17	17 3/4	7/8-9	1 1/8-7	1 5/16	12	16	4	74 lbs.	105 lbs.	144 lbs.	11.5
300	mm	336.55	247.65	79.38	44.45	31.75	11.11	102	24	95.33	431.80	431.80		23.81		12	33.60 kg	47.67 kg	65.38	292.1		
14"	in.	14 1/2	11	3 1/8	1 3/4	1 1/4	7/16	6.50	0.95	3 3/4	18 3/4	-	1-8	-	12	-	109 lbs.	178 lbs.	-	12.81		
350	mm	368.30	279.40	79.38	44.45	31.75	11.11	165	24	95.33	476.25	-	-	-	12	-	80.81 kg	80.81 kg	325.4			
16"	in.	15 3/4	12	3 1/2	2	1 5/16	7/8	6.50	1.06	6 1/2	21 1/4	-	1-8	-	16	-	135 lbs.	224 lbs.	-	15		
400	mm	400.05	304.80	88.90	50.80	33.34	22.23	165	27	165.10	539.75	-	-	-	16	-	61.29 kg	101.70 kg	381.0			
18"	in.	16 5/8	15	4 1/4	2	1 5/8	7/8	6.50	1.26	6 1/2	22 3/4	-	1 1/8-7	-	16	-	190 lbs.	265 lbs.	-	16.87		
450	mm	422.28	381.00	107.95	50.80	41.28	22.23	165	32	165.10	577.85	-	-	-	16	-	86.27 kg	120.31 kg	428.5			
20"	in.	18 7/8	15	5 1/4	2 1/2	1 3/8	7/8	6.50	1.26	6 1/2	25	-	1 1/8-7	-	20	-	316 lbs.	455 lbs.	-	18.69		
500	mm	479.43	381.00	133.35	63.50	41.28	22.23	165	32	165.10	635.00	-	-	-	20	-	143.47 kg	206.57 kg	474.7			
24"	in.	22 1/8	18	6 1/8	2 3/4	3	7/8	6.50	2.36	6 1/2	29 1/2	-	1 1/8-7	-	20	-	506 lbs.	702 lbs.	-	22.57		
600	mm	561.98	457.20	155.58	69.85	76.20	22.23	165	60	165.10	749.30	-	-	-	20	-	229.74 kg	318.71 kg	573.3			

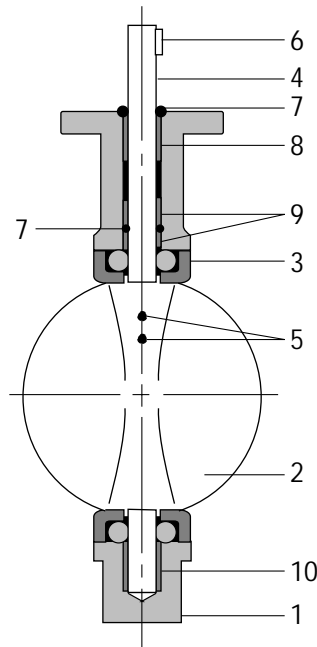

## Bill of Materials (Series 225)

Item	Description	Materials	Optional Materials
1	Body	Ductile Iron	No Options Available
2	Disc	Ductile Iron <sup>†</sup>	Aluminum Bronze, 316 Stainless Steel, Monel
3	Seat	Buna-N or EPDM	Neoprene, Hypalon, Abrasive Resistant Buna-N, Low Temperature Viton, High Temperature Viton
4	Shaft	416 Stainless Steel	2"-12": 17-4 PH, Monel
5	Taper Pin	316 Stainless Steel	Monel
6	Key	Carbon Steel	No Option Available
7	O-Ring	Buna-N	No Option Available
8	Bushing	PTFE	No Option Available
9	Bushing	PTFE	No Option Available
10	Bushing	PTFE	No Option Available

<sup>†</sup>ENP plated for 2" - 12" valves

## Bill of Materials (Series 250)

Item	Description	Materials	Optional Materials
1	Body	Carbon Steel A216 GR.WCB	316SS A351 GR.CF8M
2	Disc	316 Stainless	Aluminum Bronze, Monel
3	Seat	Buna-N or EPDM	Neoprene, Hypalon, Abrasion Resistant Buna-N, Low Temperature Viton, High Temperature Viton
4	Shaft	316 Stainless Steel	17-4 PH, Monel
5	Taper Pin	316 Stainless Steel	Monel
6	Key	Carbon Steel	No Option Available
7	O-Ring	Buna-N	No Option Available
8, 9, 10	Bushing	PTFE	No Option Available